

THIS DRAWING IS UNPUBLISHED. RELEASED FOR PUBLICATION  
 © COPYRIGHT BY TYCO ELECTRONICS CORPORATION. ALL RIGHTS RESERVED.

LOC	DIST	REVISIONS			
P	LTR	DESCRIPTION	DATE	DWN	APVD
0		PER EC-0S11-0022-05	20APR2005	AF	JGH

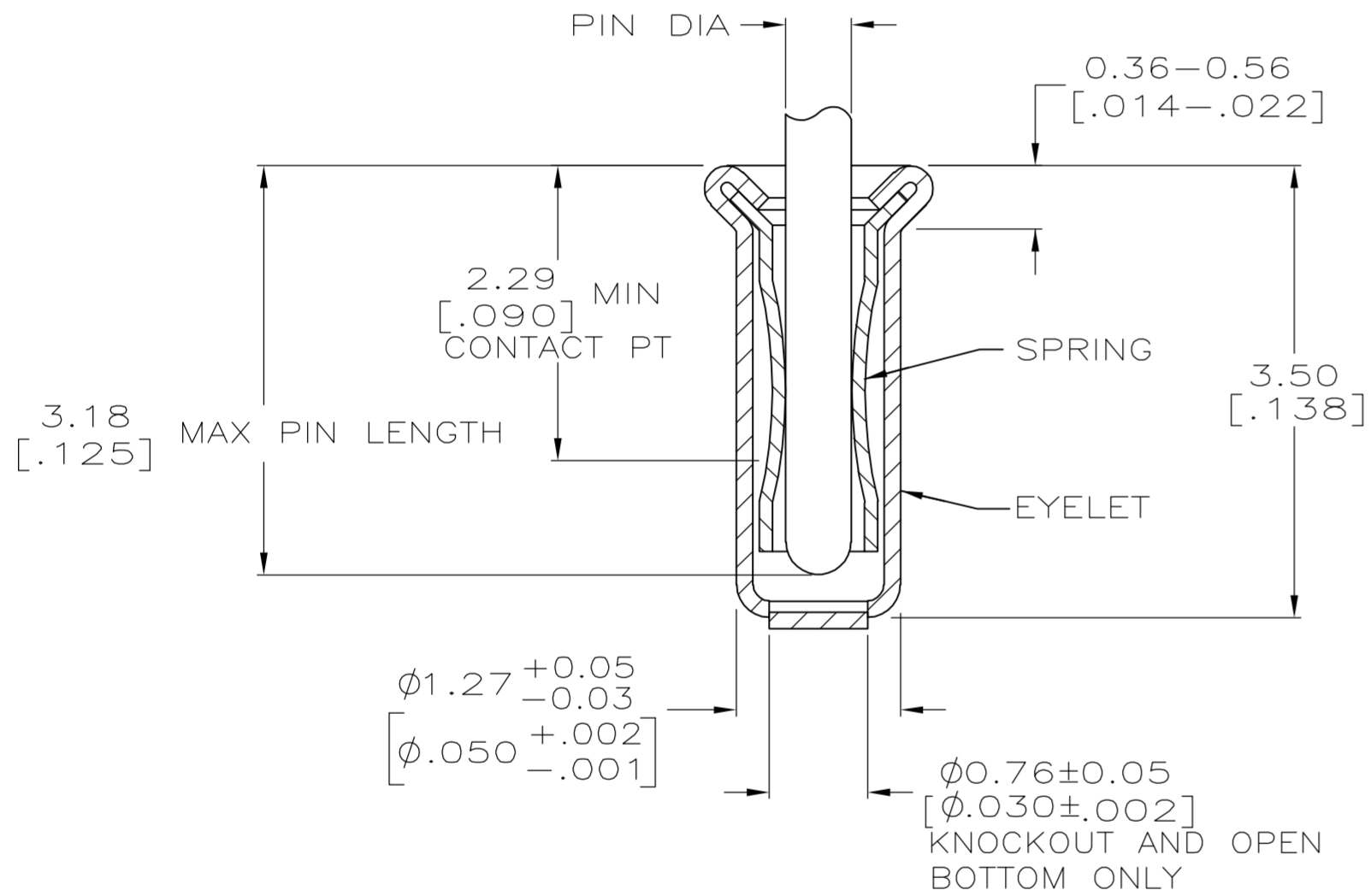
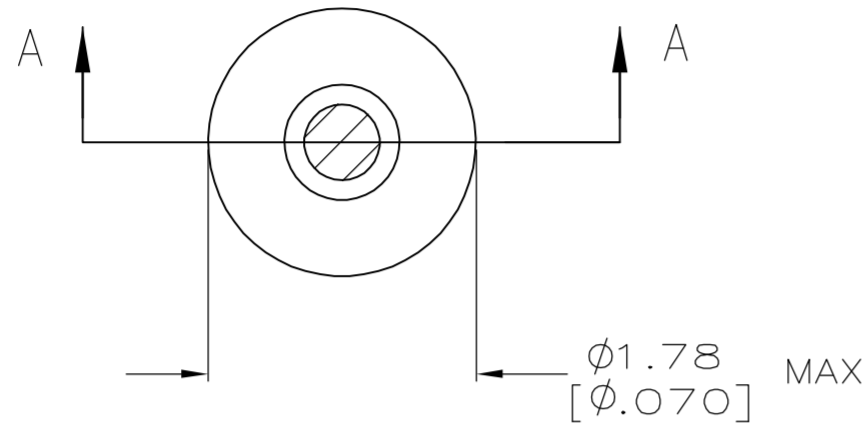

SECTION A-A

- 1. TIN PLATE PER ASTM B 545 .000254 [.000100] MIN THICK.
- 2. GOLD PLATE PER ASTM B 488 0.00076 [.000030] MIN THICK OVER NICKEL PLATE PER QQ-N-290 0.00028 [.000011] MIN THICK ON CONTACT AREA.
- 3. RECOMMENDED HOLE SIZE, PLATED OR UNPLATED:  
 MACHINE INSERTION:  $1.32 \pm 0.05$  [ $0.052 \pm 0.002$ ]  
 HAND INSERTION:  $1.32^{+0.10}_{-0.00}$  [ $0.052^{+0.004}_{-0.000}$ ]
- 4. APPLICATION TOOL PART NUMBER:  
 MACHINE NO. 682127-3  
 INSERTION HEAD NO. 682039-2
- 5. TO INSURE PROPER SPRING TENSION DO NOT EXCEED A 0.05 [.002] DIFFERENCE IN PIN DIA WHEN CHANGING TO A SMALLER PIN.
- 6. BOTTOM PLUG KNOCKOUT TOOL PART NUMBER 69729 WITH TIP PART NUMBER 69728.
- 7. MATERIAL:  
 SPRING: BERYLLIUM COPPER PER ASTM B 194  
 EYELET: COPPER PER ASTM B 152

OPEN	0.56-0.64 [ $0.022-0.025$ ] 0.46-0.53 [ $0.018-0.021$ ]	TIN 1	GOLD 2	4-5331272-3 3-5331272-9 3-5331272-5
KNOCKOUT	0.56-0.64 [ $0.022-0.025$ ]		TIN 1 GOLD 2	3-5331272-3 2-5331272-7
CLOSED	0.46-0.53 [ $0.018-0.021$ ]	EYELET	TIN 1 GOLD 2	2-5331272-5 2-5331272-3
BOTTOM TYPE	RECOMMENDED PIN DIA 5		SPRING	PART NO

THIS DRAWING IS A CONTROLLED DOCUMENT.		DWN A. FERNANDEZ-DOCK5 20APR2005	Tyco Electronics Corporation Harrisburg, PA 17105-3608	
DIMENSIONS: mm [INCHES]		CHK J. HAVENER 20APR2005	NAME MINIATURE SPRING SOCKET ASSEMBLY SERIES 2	
TOLERANCES UNLESS OTHERWISE SPECIFIED:		APVD J. HAVENER 20APR2005	PRODUCT SPEC 108-14008	
0 PLC ± - 1 PLC ± - 2 PLC ± - 3 PLC ± 0.20 [.008] 4 PLC ± - ANGLES ± -		APPLICATION SPEC 114-13152	SIZE A2	CAGE CODE 00779
MATERIAL 7		FINISH SEE TABLE	DRAWING NO C=5331272	RESTRICTED TO -
CUSTOMER DRAWING			SCALE 20:1	SHEET 1 of 1
			REV 0	